

# Kolvätätning

## Typ S-W



### Typ S-W, med låsring

**Material:**  
Nitrilgummi, stödning i Polyesterelastomer,  
styrning i Acetalplast

TOLERANSER	
∅D	<120 H11 >120 H10
∅d	<120 js11 >120 js10
L <sub>1</sub>	+0,35 +0,60
∅D <sub>1</sub>	±0,05
∅D <sub>2</sub>	±0,10
∅d <sub>1</sub>	±0,25
L <sub>4</sub>	+0,10 +0,20

∅d	C
<60	4
60 - 120	5
120 - 180	6,5
180 - 250	7,5
250 - 450	10

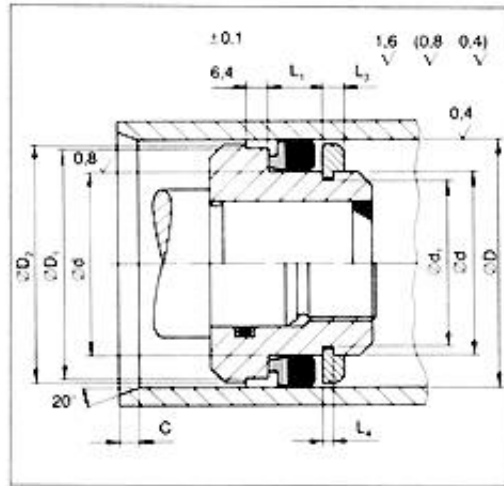

Æ D	Æ d	L <sub>1</sub>	Æ D <sub>1</sub>	Æ D <sub>2</sub>	Æ d <sub>1</sub>	L <sub>3</sub>	L <sub>4</sub>	Benämning
32	20	9,5	28,50	30,90	15,60	6,0	3,1	S 32 / 20x 9,5 W+RR
40	26	9,0	35,40	38,70	21,60	6,0	3,1	S 40 / 26x 9 W+RR
45	35	8,5	42,00	44,10	30,60	5,0	2,6	S 45 / 35x 8,5 W+RR
50	30	14,0	44,30	48,30	25,60	6,5	3,3	S 50 / 30x14 W+RR
50	35	10,5	45,45	48,70	30,60	6,0	3,1	S 50 / 35x10,5 W+RR
50	40	10,0	46,20	48,70	35,60	5,0	2,6	S 50 / 40x10 W+RR
55	40	10,5	50,40	53,70	35,60	6,0	3,1	S 55 / 40x10,5 W+RR
60	40	14,0	54,20	58,30	35,60	6,5	3,3	S 60 / 40x14 W+RR
63	45	10,5	58,40	61,60	40,60	6,0	3,1	S 63 / 45x10,5 W+RR
65	45	14,0	59,20	63,40	40,60	6,5	3,3	S 65 / 45x14 W+RR
65	50	10,5	60,40	63,60	45,60	6,0	3,1	S 65 / 50x10,5 W+RR
70	50	14,0	64,20	68,30	45,60	6,5	3,3	S 70 / 50x14 W+RR
75	55	14,0	69,20	73,30	50,60	6,5	3,3	S 75 / 55x14 W+RR
80	60	14,0	74,20	78,30	55,60	6,5	3,3	S 80 / 60x14 W+RR
85	70	12,0	80,30	83,60	65,60	6,0	3,1	S 85 / 70x12 W+RR
90	70	14,0	84,20	88,30	65,60	6,5	3,3	S 90 / 70x14 W+RR
95	75	14,0	89,20	93,30	70,60	6,5	3,3	S 95 / 75x14 W+RR
100	80	14,0	94,20	98,30	75,60	6,5	3,3	S 100 / 80x14 W+RR
104,5	85	12,5	98,70	102,80	80,60	6,0	3,1	S 105,5/ 85x12,5 W+RR
105	85	12,5	99,10	103,30	80,60	6,5	3,3	S 105 / 85x12,5 W+RR

105	85	14,0	99,10	103,30	80,60	6,5	3,3	S 105 / 85x14 W+RR
110	90	12,5	104,10	108,30	85,60	6,5	3,3	S 110 / 90x12,5 W+RR
120	100	12,5	114,10	118,30	95,60	6,5	3,3	S 120 / 100x12,5 W+RR
125	105	12,0	119,10	123,30	100,60	6,5	3,3	S 125 / 105x12 W
130	110	12,5	123,10	128,00				S 130 / 110x12,5 W
150	125	14,0	143,00	148,00				S 150 / 125x14 W
165	145	14,0	159,20	163,00				S 165 / 145x14 W
250	230	14,0	242,70	248,00				S 250 / 230x14 W
300	270	20,0	292,90	298,00				S 300 / 270x20 W
330	300	20,0	322,90	328,00				S 330 / 300x20 W
350	310	20,0	343,10	348,00				S 350 / 310x20 W
360	330	20,0	353,10	358,00				S 360 / 330x20 W
400	370	20,0	392,90	398,00				S 400 / 370x20 W
440	410	20,0	432,90	438,00				S 440 / 410x20 W